

Geothermal power generation in Indonesia, a country within the ring of fire: Current status, future development and policy



Nugroho Agung Pambudi^{a,b,*}

^a Mechanical Engineering Education, Universitas Negeri Sebelas Maret, Jl. Ir. Sutami 36A, Surakarta 57126, Indonesia

^b International Institute for Carbon-Neutral Research (WPI-I2CNER), Kyushu University, 744 Motoooka, Nishi-ku, Fukuoka 819-0395, Japan

ARTICLE INFO

Keywords:

Geothermal
Indonesia
Current status
Policy
Power plant

ABSTRACT

Indonesia has a huge of geothermal potential in the world since the location of the country is in the ring of fire in volcano line. Approximately 28.91 GW of geothermal energy potential is spread across 312 locations on several islands such as Java, Sulawesi and Sumatra, Bali, Nusa Tenggara and Sulawesi. However, the utilization ratio of this potential is small, less than 5%, generate 1533.5 MW electricity from 11 geothermal power plant such as Gunung salak, which has a capacity of 377 MW, 270 MW of darajat; 227 MW of Wayang windu, 235 MW of Kamojang, 60 MW of Dieng, 55 MW of Patuha. 165 MW of Ulubelu, 12 MW of Sibayak, 120 MW of Lahendong, and 10 MW of Ulumbu. Most of the geothermal reservoirs are water-dominated. However, two reservoirs in Gunung salak and Lahendong, are vapor-dominated. Therefore Dry steam power plant is employed in those two plant.

In the current situation, Indonesia has aggressive plans for future development geothermal power plant. In 2005 geothermal roadmap target had been released to produce 9500 MW. However, this target then evaluated to more realistic to 7000 MW in 2025. Last year in 2016 additional of the 35 MW Kamojang unit-5, 40 MW of Lahendong 2 × 20 MW and 55 MW of Ulubelu unit-3 has been inaugurated. Furthermore, five more plants will be operated in Ulubelu, Lahendong and Sarulla, Karaha bodas and Lamut balai. To promote more development of geothermal energy, government has issued laws such as Law No. 21 of 2014 represents a change from the policy of Act No. 27 of 2003. An important point of revision is that geothermal power generation is no longer classed as a mining operation. The law also describes the price of geothermal energy in three different area divisions, each with a different benchmark price.

1. Introduction

The country of Indonesia is made up of more than 17,000 islands, of which 922 are permanently inhabited. It is located in Southeast Asia, with a tropical climate, and contains many beautiful forests as well as wide diversity in plants and animals. The expanse of this beauty may disguise the frightening fact that Indonesia is located over the seismic lines of the “Ring of Fire” that stretches around the Pacific from southeast Australia to the American Southwest as shown in Fig. 1. Along with this path, frequent seismic activity occurs. As tectonic plates shift, they become triggers of earthquakes, volcanic activity, and other potential natural disasters. Therefore earthquakes come often. Once magma forms beneath the earth's crust, it will look for gaps to rise to

the top because of the great pressure it is under. Over a long period, this process can form a volcano. The magma is also a source of heat to fluids trapped deep below the earth's surface called geothermal. Sometimes it heated water comes to the surface in hot springs or geysers. In any case, this heat which continually rises from the magma to water trapped under the surface is the origin of what we call geothermal energy. Therefore, Indonesia's location on the Ring of Fire makes it a storehouse of geothermal energy.

In Indonesia, total geothermal potential is estimated at 28,910 GW, drawn from 312 fields located across several islands. Unfortunately, despite having the highest geothermal potential, it draws on less than 5% of this capacity. The total installed capacity is 1533.5 MW and this shows a low utilization ratio with stand in the third rank of geothermal

Abbreviations: CIDA, Canadian International Development Agency; GFZ, German Research Centre for Geosciences; BPPT, Agency for the Assessment and Application of Technology in Indonesia; Pertamina, Indonesian state-owned oil and natural gas corporation; MEMR, Ministry of Energy Mineral Resources, Indonesia; NEDO, New Energy and Technological Development Organization; VSI, Volcanological Survey of Indonesia; GSJ, Geological Survey of Japan; PLN, State Electricity Company; PGE, Pertamina Geothermal Energy; MW, Mega Watt; GW, Giga Watt; Mwe, Mega Watt Electricity; NTT, East Nusa Tenggara; HCL, Himpurna California Energy Ltd.; JOC, Joint Operation Contract; ASL, Above Sea Level; UGI, Unval Geothermal Indonesia; SRH, Steam Receiver Header

* Correspondence address: Mechanical Engineering Education, Universitas Negeri Sebelas Maret, Jl. Ir. Sutami 36A, Surakarta 57126, Indonesia.

E-mail address: agung.pambudi@staff.uns.ac.id.

<http://dx.doi.org/10.1016/j.rser.2017.06.096>

Received 30 April 2016; Received in revised form 10 March 2017; Accepted 23 June 2017

Available online 01 July 2017

1364-0321/© 2017 Elsevier Ltd. All rights reserved.

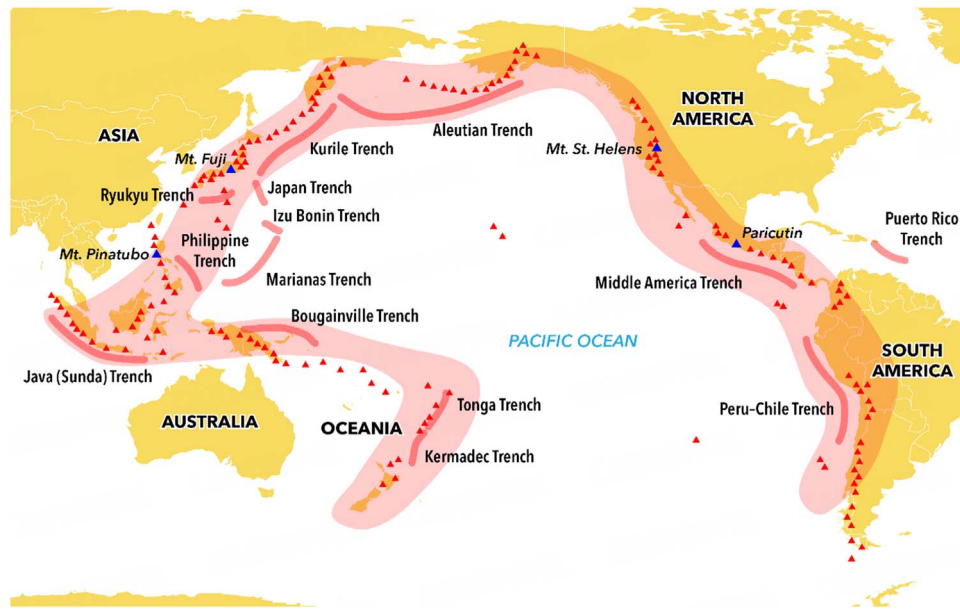

Fig. 1. The circum-pacific “ring of fire” [1].

Table 1
Installed capacity, potential, utilization ratio and power generation share.

Country	Update capacity 2016 (MW)	Estimation hydrothermal Potential	Utilization ratio %	Power generation share (%)
USA	3700 [2]	16,457 [3]	20.9	0.42 [4]
Philiphine	1870 [5]	4335 [6]	45	14 [7]
Indonesia	1533.5	28,910	5.3	2.15 [8]
Mexico	1058 [5]	2310 [9]	45.8	
New Zealand	1005 [5]	No data	No data	22 [10]
Japan	519 [5]	23,400	2.2	0.2

power produced. Indonesia still relies on fossil energy resources, which has a very large share in total primary energy supply. Definitely this is a critical situation for energy security in the future. As shown in Table 1, the installed capacity, resources potential, utilization ratio and power generation share is presented to give an overview how the development geothermal energy in each country. USA has a dominated of geothermal energy utilization with their huge capacity of 3700 MW from 24,000 its resources potential and the utilization ratio is 15.8. However, in USA this total capacity is very low in power generation share at about 0.42%. In Philiphine furthermore, the utilization of geothermal power is better by developing 1970 MW from its 4335 MW resources potential. This is the highest utilization ratio from those six

Table 2
Field location, number, potential of current situation of geothermal energy In Indonesia [15].

Field location	Number	Potential (MWe)					Total (MWe)	Installed (MWe)	
		Resources		Reserve					
		Speculatif	Hypothetic	Possible	Probable	Proven			
Sumatra	93	3183	2469	6790	15	380	12,837	122	
Jawa	71	1672	1826	3786	658	1815	9575	1264	
Bali-Nusa Tenggara	33	427	417	1013	0	15	1872	12,5	
Kalimantan	12	145	0	0	0	0	145	0	
Sulawesi	70	1330	221	1374	150	78	3153	80	
Maluku	30	545	76	450	0	0	1071	0	
Sulawesi	3	75	0	0	0	0	75	0	
Total	312	7377	5009	13,413	823	2288	28,910	1478.5	
		12,386		16,524					
		28,910 MWe potential in total							

countries and this geothermal energy support 14.2 power generation mix. However with a huge potential since the location in the ring of fire, is not utilize the resources optimally since the utilization ratio is about 4.97% and the share of power generation is only about 2.15%.

There are a lot of issues which makes geothermal development is challenging such as government policy, regulation, human resources, incentive infrastructure. However other countries are also facing this situation in developing of electricity from geothermal. In Japan however within lowest utilization at 2.2% has several issues such as the location of the most geothermal field is within the conservation park and Japanese hot spring bathing business interest. This paper will discuss the current situation of geothermal power generation in Indonesia, including the latest update of the geothermal capacity in 11 plants and future development of several fields which are in the processing stage of development, and the tariff subsidies policy as well as geothermal laws. The first binary geothermal power plant which is developed in Lahendong will also be covered in this paper.

2. Current situation of geothermal power generation

Geothermal development in Indonesia is small if compared to potential resources and utilization ratio. The capacity of the Geothermal power plants increased by only 193 MW since 2009 [11]. In the Table 2, Field location, number, potential, total and installed

capacity are presented. The resources potential is to include resources and its reserve and it expand to speculative, hypothesis, assured, possibility and proven. In the speculative resources the estimation is based on the presence of manifestation surface while for hypotectic resources is determined based on the geological and geochemical surveys [12]. Furthermore in reserve potential more research geoscience is carried out. Speculative also can be determined based on the simple statistic while for hypotectic can be determined based on the volumetric methods [13]. In the geothermal reserve it is include in the three term: possible, probable and proven. Possible reserve is the estimation based on the detail investigation while probable is not only detail investigation but also based on the drill exploration identification and preliminary of feasibility study [14]. Furthermore, in proven reserve inform a detail of well data such as the geothermal fluid flow capacity. In this classification however do not indicate the enthalpy classification. Therefore for power generation technology type can not be approached with this method.

Based on the previously term of geothermal potential, Sumatra has the biggest potential with 93 field, 3,3183 speculative and 2469 hypothetic resources. Potential energy from both speculative and hypothetic resources and likely reserves totals 12,837 MW. However, the island has only 122 MW installed, revealing a wide gap between its geothermal capacity and current utilization. Jawa, meanwhile, has only 71 locations of potential geothermal fields, but has the biggest installed capacity of all Indonesia's islands: 1224 MW. Jawa's speculative and hypothetic resources are over 3000 MW, but its assured and proven reserves are even higher at 3786 MW and 1815 MW respectively. Its total potential is 9575 MW. The third most productive island is Sulawesi, with 70 geothermal field locations, speculative and hypothetic resources of over 1500 MWe, and reserves of 1602 MWe. However, of that total capacity of more than 3100 MWe, only 80 MWe are installed. Bali-Nusa Tenggara, with 33 geothermal fields, has only 12.5 MWe installed of a total capacity of 1872. The islands of Kalimantan and Maluku have no installed geothermal capacity, but they do have 12 and 30 geothermal fields respectively and Maluku has a likely total capacity of over 1000 MWe. Filling these gaps would do much to realize the country's potential. Indonesia as a whole has 12,386 in speculative and hypothetic geothermal resources and 16,524 MWe in reserves. Of these 28,910 MWe in total potential, only 1403 MWe have been installed.

In the power generation plant, there are currently 11 existing plants as shown in Fig. 2. The biggest plant in Gunung salak generates 377 MW. Near this area, the Darajat, Wayang windu, Kamojang and Patuha generates 270 MW, 227 MW, 235 Mw and 55 MW, respectively. Move to central of Jawa, the Dieng power plant generates 60 MW. Together, these six power plants in Jawa Island produce almost 1224 MW, the vast majority of geothermal energy installed in Indonesia. There are also two plants on the island of Sumatra to the

northwest of Jawa: the Ulubelu plant, which produces 165 MW, and the Sibayak plant, which produces 12 MW. Sulawesi, an island north-east of Jawa, has the plant that is farthest from the others, Lahendong, which produces 80 MW. The smaller island of Bali, directly east of Jawa, has two small geothermal power plants: Mataloko, which generates 2.5 MW, and Ulumbu, which generates 10 MW.

In the power plant technology, Table 3 shows an update of detail each technology including unit capacity, and reservoir type. The newest updates is from Kamojang unit-5 that recently is operated in last of December 2016 with additional capacity of 35 MW. Most of the technology used in geothermal power plant in Indonesia is single flash system since most of the reservoir condition is water-dominated. However, Kamojang and Darajat have vapor-dominated reservoir. Therefore, dry steam power plant is employed. Basically, there are six geothermal power plant types including binary, back pressure, single-flash, double-flash, triple flash and dry steam. In the world there are 5079 MW of single-flash. 2863 MW of dry steam, 2544 MW of double-flash and 1790 MW of binary [5]. However in unit, binary has highest number by 286 unit.

3. Detail of power plant

This part describes the detail of power plant including reservoir information from 11 geothermal field.

3.1. Sibayak

Sibayak geothermal field is located in the area around the mountain Sibayak, Karo District, North Sumatra. The location elevations is between 1400 and 2200 m and there are three active volcanoes: Mt. Pintau (2212 m), Mt. Sibayak (2090 m) and Mt. Pratetekan (1844 m) [16]. Preliminary studies over an area of 20 × 20 km including Mt. Sibayak were carried out during 1989–1991 by drilled five wells: SBY-1, SBY-2, SBY-6, SBY-7, SBY-8. Temperature were measured and shows The maximum temperatures in wells SBY-1, SBY-6 and SBY-8 were to be 225 °C, 278 °C and 258 °C, respectively [17]. Sibayak power plant is started to operate in 2007 and in the current situation it has 12 MW capacity from two unit of 2 × 5 MW and one monoblok 2 MW power station.

3.2. Ulubelu plant

The Ulubelu geothermal field is located in the village of Pagar alam and Muaradua, approximately 45 km from the district of Talangpadang or about 125 km from the city of Bandar Lampung. The power plant began operating in 2012, and it is operated by two of company PLN and PGE. Currently total electricity produced is 165 MW by PLN while the steam is produced by PGE. The steam temperature produced has

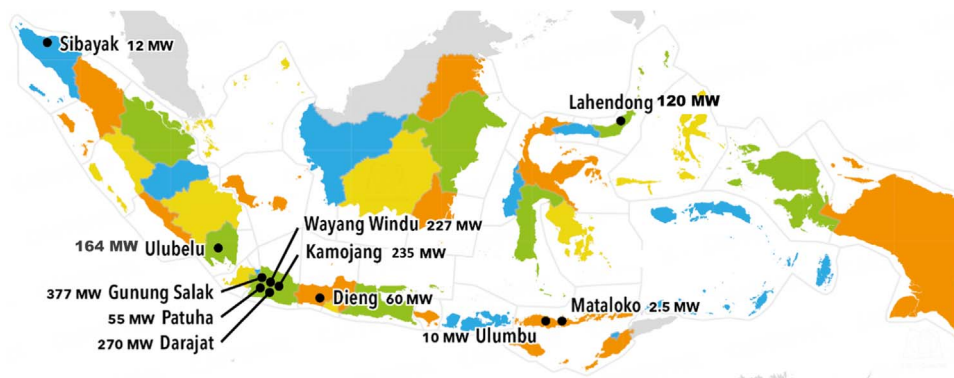

Fig. 2. Location of 11 geothermal power plants in Indonesia.

Table 3

An update of geothermal power plant in Indonesia.

No	Field	Unit	Total Capacity	Reservoir	Technology
1	Sibayak	Monoblok 2 MW. Unit-2–3, 2 × 5 MW	12 MW	Water dominated	Single-flash
2	Ulubelu	Unit-1–3; 3 × 55 MW	165 MW	Water dominated	Single-flash
3	Salak	Unit-1–3, 3 × 60 MW. Unit 4–6 3 × 65.6 MW	377 MW	Water dominated	Single-flash
4	Wayang Windu	Unit-1: 110 MW Unit 2: 117 MW	227 MW	Water dominated	Single-flash
5	Patuha	Unit 1: 55 MW	55 MW	Water dominated	Single-flash
6	Kamojang	Unit-1: 30 MW Unit 2–3: 2 × 55 MW Unit 4: 60 MW Unit 5: 35 MW	235 MW	Vapor dominated	Dry steam plant
7	Darajat	Unit-1: 55 MW Unit-2: 94 MW Unit 3: 121	270 MW	Vapor dominated	Dry steam plant
8	Dieng	1 × 60 MW	60 MW	Water dominated	Single-flash
9	Lahendong	Unit 1–6: 6 × 20 MW	120 MW	Water dominated	Single-flash
10	Ulumbu	Unit 1–4: 4 × 2.5 MW	10 MW	Water dominated	Single-flash
11	Mataloko	2.5 MW	2.5 MW	Water dominated	Single-flash
Total			1533.5 MW		

average temperature of 265 °C with average enthalpy 1160 kJ/kg [18]

Ulubelu geothermal power plant consists of three units, Ulubelu unit-1, unit 2 and unit-3. In 2017 ulubelu unit-4 is planning to operated with 55 MW. Exploration drilling activities on this project began in 2007 [19]. A preliminary survey of geothermal energy began in 1986 throughout the region of Sumatra, including Ulubelu. Further exploration activities started in 1991 under the coordination of Pertamina Unit II Plaju. In 1994, slim hole drilling exploration was carried out, but activities begin faltered after that. Moreover, development was stalled by an economic crisis began with the financial crisis in the second half of 1997. Activities resumed in 2007 with the drilling of exploration wells UBL-01 and UBL-02, followed by drilling of well UBL-03 in 2008. The Unit 1 geothermal power plant started operation in September 2012 [20].

3.3. Gunung salak

Gunung salak is a geothermal location within the national park of Salak Mountain at an altitude of 1400 m ASL. The area, also known as Awi bengkok geothermal system, is administratively located in two districts, Sukabumi and Bogor, and approximately 100 km from the capital of Indonesia, Jakarta. There are 100 wells operating at Gunung salak including production, reinjection and monitoring wells. The plant is managed by Chevron Geothermal Salak (CGS) and has a water-dominated reservoir. Therefore, flash technology is used to convert the hot fluid into electricity. The temperature of the geothermal reservoirs at Gunung salak ranges from 215 to 312 °C. The area of the reservoir is approximately 7 km² with an average thickness of 1700 m.

The geothermal development project at Gunung salak started in 1982 by Unoval Geothermal Indonesia (UGI) in cooperation with Pertamina [21]. It continued by drilling the Awi bengkok and Pelabuhan Ratu area. Because of the low potential in Pelabuhan ratu, the project stopped and focus remained in the Awi bengkok area. After the exploration phase was completed, two power plant units were built, generating 2 × 55 MW. The plant operated in this way until 1994. From 1995–1997, additional units 3, 4, 5 and 6 were constructed with a capacity of 55 MW each, thereby providing a total capacity increase to 330 MW [21]. Currently, after upgrades to all 6 units, the total capacity of Gunung salak has reached 377 MW [22]. Electricity produced by Gunung salak is sent to the electric grids of Java, Madura and Bali.

3.4. Wayang windu

The Wayang windu geothermal field, operated by Star Energy, is located in Pengalengan Regency, West Java, which is about 40 km to the south of Bandung, West Java province. It lies at an elevation of about 1700 m above sea level. Geothermal activity in this field is manifested in the forms of hot springs, fumaroles, and steaming ground. These manifestations arise naturally from open fractures in the rocks over the fluid source within the reservoir. The temperature of

this reservoir is approximately 260–325 °C at a depth of 1300–2500 m [23]. Wayang windu is one of the water-dominated reservoirs. However, to the north of the reservoir, the vapor fraction increases and it likely becomes vapor-dominated. Wayang windu is one of five operating geothermal fields in Java.

The geothermal power plant at Wayang windu has two generating units with a total capacity of 277 MW, which are connected to the Java-Bali interconnection network. A geological survey began in 1985 and the first wells commenced drilling in 1991. The construction of the unit-1 completed in 1999 and the commissioning as well as commercial operation started in 2000 [24]. Unit 2 operated in 2009. The Unit 1 geothermal power plant has a capacity of 110 MW and is supplied by 13 production wells. Unit 2 has a capacity of 117 MW with 6 production wells. There are additionally 5 injection wells. Operations in Wayang windu geothermal power plant were stopped in early May 2015 because of landslides in the area. The plants then reopened in early September 2015 [25] (Fig. 3).

3.5. Patuha

The Geothermal Field Operations at Patuha Rancabali are administratively located in the Bandung regency, West Java Province, at coordinates 7° 10'36,7" latitude and 107° 24'30,7" BT. It is about 50 km southwest of the city of Bandung. The Patuha geothermal system has a vapor-dominated reservoir. There are many geothermal manifestations near Patuha such as fumaroles, with a temperature of 93 °C, acidic hot springs and hydrothermal alteration. The hot springs are located around northern Patuha and have temperatures ranging from 35 to 83 °C and the water flow between 2–15 l/s [26]. Reservoir temperatures range between 215–230 °C and pressure is as much as 30 bars.

The Patuha geothermal field in West Java, has nine production wells and four non-commercial wells that are intended for power generation. The non-commercial wells can be used as injection wells. Enthalpy production wells have ranged between 2400 and 2700 kJ/kg [27]. The first unit (55 MW) at Patuha was completed in 2014 and since 2015 it has been producing at full capacity. The geothermal field Patuha is managed by PT. Geodipa, who is also the manager of a geothermal field in Dieng.

3.6. Kamojang

Kamojang, located approximately 40 km south of the city of Bandung in West Java province with temperature from 15 to 200 °C and annual rainfall reach 2.885 mm [26]. It is an area where geothermal energy began to be developed. In 1918, JB Van Dijk suggested utilizing the geothermal resources in Kamojang [28]. This was the era of the Dutch East Indies, before Indonesia became an independent state. It was also only a few years after the first geothermal power station at Larderello, Tuscany was being developed. Indeed, the

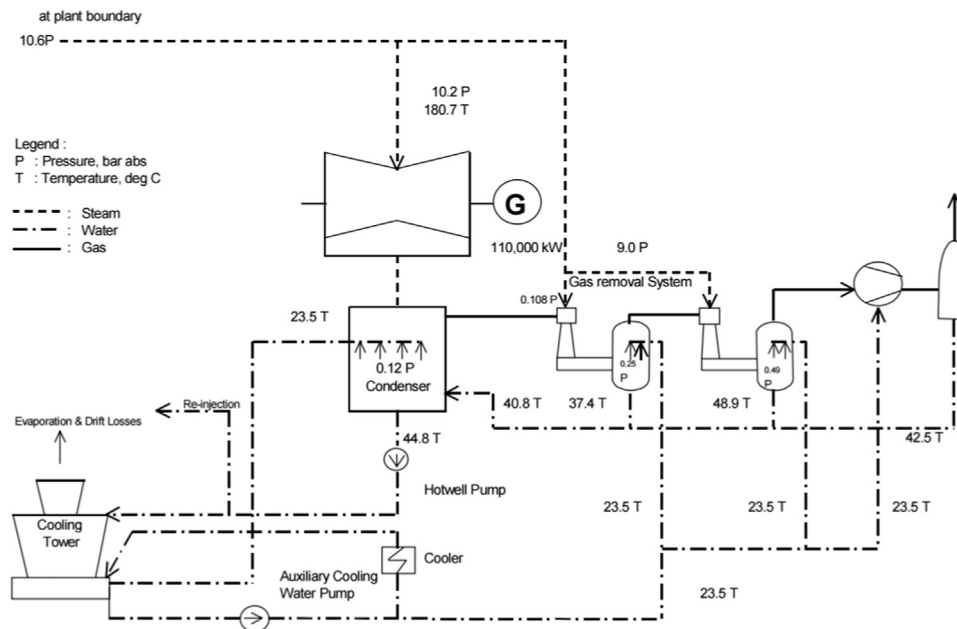

Fig. 3. Schematic diagram of the Wayang windu geothermal power plant [25].

process of geothermal development was born almost simultaneously with the operation of the first geothermal plant in Larderello.

The proposed process was followed by exploration activities for the first time in 1926. By 1928, there were five instances of drilling for exploration, but after several attempts only one well, KMJ-3, produced dry steam at a depth of 66 m. Exploration projects then stalled, to resume long after Indonesian independence, in 1972. Then geological mapping and geochemical and geophysical exploration were carried out. More detailed exploration was resumed by Pertamina and PLN in collaboration with New Zealand in 1974. This exploration project was completed in 1977, followed by the construction of the first geothermal unit in Kamojang [29].

This plant was first operated in 1982 with a capacity of 30 MWe. In 1988, two more units operated generating 55 MW. In August 2008, unit IV of the Kamojang operation had a capacity of 60 MW. Thus, after operating for more than 30 years, the geothermal power plants at Kamojang have a total capacity of 235 MW. New exploration activities have identified sufficient resources to increase the existing plant by an additional 35 MWe with Unit V.

Kamojang's system is a vapor-dominated field, and a dry steam power plant has been used to produce electricity. The temperature of the reservoir is around 235–245 °C with a pressure of 31–38 kg/cm² [30]. Total production of the wells at Kamojang is very volatile. From 2000 to 2008, it increased sharply to a peak of 12,612 t. According to the latest data, this figure then decreased to 11,256 t in 2013 [29]. The schematic diagram of dry steam kamojang geothermal power plant is described in Fig. 4.

In the Kamojang power plant unit 2–3, the plant unit is equipped with Steam Receiver Headers (SRH) to prevent steam fluctuations which can directly impact electricity production. The SRH are connected with a vent valve system which discharges excessive steam entering the plant. After passing through SRH steam enters into a separator, which removes debris and other substances from steam by employing centrifugal force. The function of this separator is different from single-flash technology, which is used to separate brine from steam. To ensure high quality, steam is then passed through a demister. This is a device which is employed to remove water droplets from steam. It utilizes turbulence and collision force between high speed steam and its own components. The trapped water is then drained through the flash tank. After the demister majority of the steam enters a turbine, whereas a small quantity of steam is diverted to a steam

ejector in the gas removal system. For safety measures, the system is equipped with a main stop valve which protects it from overpressure and other emergency situations.

3.7. Darajat

The Darajat geothermal power plant is located approximately 22 km west of the city of Garut, West Java. This geothermal area is about 10 km southwest of the geothermal field in Kamojang. Darajat has characteristics similar to Kamojang with a vapor-dominated reservoir. In that respect, these two reservoirs differ from the more common geothermal water-dominated reservoir in Indonesia. The Darajat geothermal power station produces a total of 270 MW from 3 units. Darajat Unit I, which started operation in 2000, generates 55 MW; Darajat Unit II, which started construction in 2004 and began operating in 2007, generates 95 MW and Darajat Unit III generates 121 MW.

Darajat and Gunung salak are owned by Chevron which is the largest geothermal producer in the world with their 1273 MW capacity and it is developed around 27% world geothermal power [32]. Because of its vapor-dominated reservoir, Darajat employs a dry-steam power plant to produce electricity. Steam from the reservoir flows to the surface and past a pressure regulator valve that keeps its pressure steady. From this valve, the steam flows into the scrubber, which improves its quality by eliminating moisture. The dry steam flows to a turbine and spins the turbine blade. This turbine rotation is what enables the generator to produce electricity. Steam coming from the exhaust turbine flows into the condenser to keep pressure in the turbine outlet.

3.8. Dieng plant

The Dieng Plateau is located at an altitude of 2000 m above sea level within Central Java province. Dieng is a complex of volcanoes, with manifestations such as hot springs and fumaroles [33]. Geothermal development in Dieng has been carried out since the time of the Dutch government, which in 1918 began investigation of the area's geothermal potential. In 1964–65, Unesco recognized Dieng as a geothermal resource that had very good prospects in Indonesia. By 1970 USGS was performing geophysical surveys and drilling six shallow wells, with a maximum depth of about 150 m. The tempera-

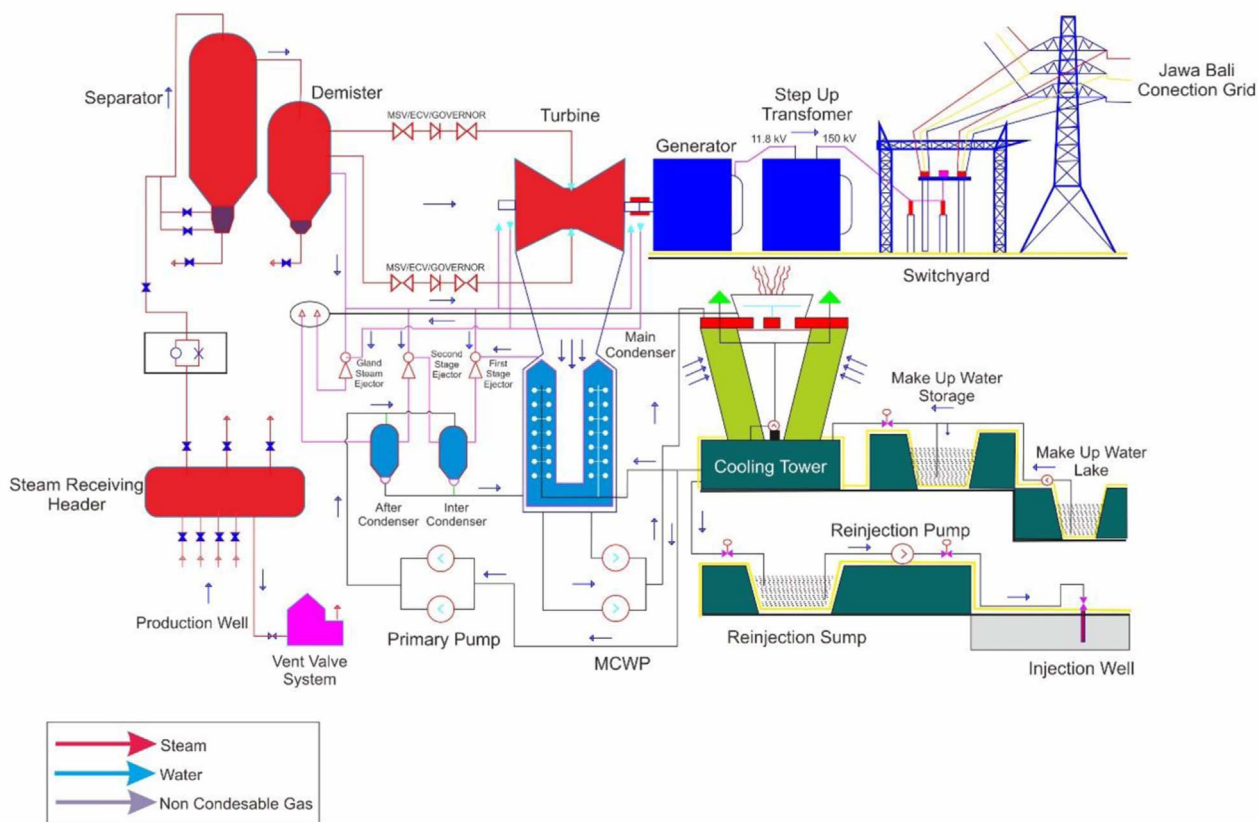

Fig. 4. Schematic diagram of Kamojang geothermal power plant [31].

tures recorded in 1973 ranged from 92 to 173 °C. Between 1976 and 1994, Pertamina completed 27 test wells, and in 1993 began to produce electricity through operation of a monoblock power plant (2 WM). HCL (Himpurna-California Association of Energy) and Pertamina furthermore held Joint Operating Contracts (JOC) [34].

Dieng's installed capacity is 60 MWe, but there are more than 300 MW of untapped potential in exploration. In 2008, the installed capacity had an immediate and significant drop by 20 MW. Therefore the electricity supplied to grid was only 40 MW, and in 2010 it declined again to only 20 MW. This decrease was caused by a very high silica content, averaging more than 1000 ppm (see Fig. 5) [35]. Geodipa Energy attempted to restore the production capacity of the geothermal steam with the workover of production wells, in particular by cleaning the well bore holes, which had narrowed in diameter from a crust of SiO₂.



Fig. 5. Silica scaling in Dieng power plant, which is an obstacle of fluid flow [35].

3.9. Lahendong

The Lahendong geothermal field is located in Tomohon, North Sulawesi. Geothermal development was started there in 1971 with survey team visits involving the Directorate of Geology of Bandung, PLN, and geothermal experts from New Zealand, followed in 1977–1978 by a survey team from the Canadian International Development Agency (CIDA). Since 1982 Pertamina has conducted activities in Lahendong including geological surveys, geochemistry, and geophysics. In 1995, an MOU between Pertamina and PLN was issued to build a geothermal power plant (capacity 1 × 20 MW) in Lahendong, North Sulawesi [36].

The Lahendong plant has a total production capacity of 120 MW from Units 1–6. The first unit is started operation in 2001. It continues by unit-2 in 2007. Unit-3 and unit-4 are operate n 2009. New capacity from unit-5 and 6 just been inaugurated in last of december with capacity of 2 × 20 MW. The geothermal field of Lahendong has nine production wells and two injection wells [37]. The reservoir is a water-dominated system with temperatures ranging from 200 to 340 C.

In Lahendong there is binary power plant research collaboration Germany-Indonesia by involving GFZ Potsdam and Agency for the Assessment and Application of Technology in Indonesia (BPPT) as well as PT Pertamina Geothermal Energy (PGE). The hot brine with 170 °C comes from LHD-5 is used to heat the water using a Heat Exchanger as shown in Fig. 6. The hot water is then used to heat and evaporate the organic working fluid (n-pentane) is circulated inside the unit Binary plant. Steam (Vapor) the working fluid is then spins a turbine and generator to produce electricity. Furthermore, after turning the turbine, the steam is condensed using cold water from the cooler dry. This binary collaboration is started in 2009 and construction on the site began in January 2016 and was completed in September 2016. In the current situation Binary unit commissioning is currently underway and

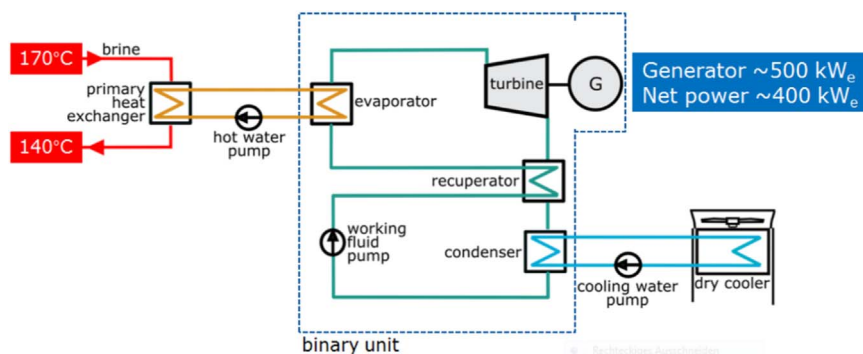

Fig. 6. Schematic diagram Binary power plant in Lahendong, Germany- Indonesia project [38].

Table 4
Future development.

No	Plan	Capacity (MW)				
		2015	2016	2017 [15]	2018 [15]	2019 [15]
1	Kamojang unit-5	35				
2	Ulubelu 3 & 4		55	55		
3	Lahendong 5 & 6		40			
4	Sarulla			110	119	
5	Karahan			30		60
6	Lumut balai			55	55	55
7	Muaralaboh			70		
8	Tulehu				20	
9	Rantau dedap				220	
10	Radja basa				110	110
11	Huluais				55	55
12	Dieng				55	55
13	Patuha					110
14	Sungai penuh					55
15	Cisolok					45
16	Kotamobagu					40
Total per year		35	95	320	634	585
Total capacity		1533.5	1533.5	1853.5	2478.5	3063.5

this year hope the first binary operation is operated [38,39].

3.10. Mataloko

Another geothermal power plant is located Bajawa Mataloko, Ngada regency, East Nusa Tenggara. This area is a continuation of the magma pathway known as the Ring of Fire through Sumatra, Java and Bali. Since this situation, east Nusa Tenggara has the prospect of a good future in geothermal potential to resolve power shortage in the island. Based on the MEMR report, Maloko field has high enthalpy fluid type and it has proved by the well text exploration and it also has a superheated dry steam reservoir. Based geophysical data there are 5 km³ prospect area with neutral pH [37].

Identification of Mataloko geothermal field is in started 1997 by Volcano logical Survey of Indonesia (VSI) research including geologic mapping, geochemical prospecting and geophysical survey. It then continues 1997–1999 by intensive explorations by Volcano logical Survey of Indonesia (VSI), Geological Survey of Japan (GSJ) and New Energy and Technological Development Organization (NEDO) within a cooperative research project “the exploration of small-scale geothermal resources in the eastern part of Indonesia” [40]. in the current situation The Mataloko power plant is operated by PLN, MEMR, and the district government of Ngada with a capacity of 2.5 MW.

3.11. Ulumbu

Ulumbu is a geothermal power plant located in the Satarmese district, Manggarai regency, East Nusa Tenggara (NTT). Geothermal in

Ulumbu made to overcome the electricity shortages in nearly district. Expensive diesel power plant has been fully operated before ulumbu geothermal is started. In the current situation, PLN operate which the total capacity 4×2.5 MW. The history of development geothermal energy in Ulumbu is started in 1989 when PLN collaboration with the New Zealand promoting the ulumbu mini geothermal project. It then continue by exploratory drilling in 1994–1995 for Two production wells ULB-01 and ULB-02 and one reinjection. Well ULB-01, ULB-02 and reinjection well was drilled with the depth of 1887, 878.7 and 951 m. This drilling activities indicates that the mini geothermal power plant can be operated in Ulumbu [41]. By the continue investigation, Ulumbu shows the possible reserve at 187,5 MW [42]

Commercial drilling of wells in Ulumbu began in 2003, and three wells had been drilled by 2006. The plant's first unit in Ulumbu started operations in 2011 by producing 2.5 MW [43]. In 2012, the second unit produced the same amount of power. Ulumbu has estimated geothermal reserves of 187.5 MW (MW), with proven reserves of 12.5 MW and 5 MW of power newly installed. Ulumbu has 2 production wells with depths of nearly 1500 m.

4. Future development and policy

In the last ten year, geothermal power plants development is not too active in comparison with the Philippines and USA. However, in recognition of the potential resources is waiting to be unlocked, more aggressive plans have been put forward for future development through 2019. Basically in 2005, the government released road map of geothermal development and it has a target of 9500 MW plant in 2025. However this target to be unrealistic since slow of deployment. Furthermore future target is then evaluated to be 7000 MW in same year of 2025. Table 4 shown a future development stage in 2015–2019. In 2015, the Kamojang unit-5 has been installed by 35 MW. In 2016, two more plants have been inaugurated in Ulubelu unit-3 and Lahendong unit5 and unit6 increasing by 95 MW. In 2017 Ulubelu unit-4, sarulla, Karahan, lumut balai and Muaralaboh will be operated giving 320 MW additional capacity. These changes will bring Indonesia's total installed capacity to 1853.5 MW.

The year of biggest planned growth is 2018, which will see another 119 MW from Sarulla, 55 from Lamut balai, and additions of 20 MW from the Tulehu plant, 220 MW from Rantau Dedap, 110 from Radja basa, and 55 each from plants in Huluais and Dieng. In total, geothermal capacity will jump by 634 MW in 2018 for a total of 2478.5. The last year of the plan, 2019, expects an increase in 60 MW from Karahan, 55 MW from Lamut balai, 110 MW from Radja basa, 55 MW from Huluais, 55 MW from Dieng, 110 MW from the Patuha plant, 55 MW from Sungai penuh, 45 MW from Cisolok, and 40 MW from Kotamobagu. In total, 16 different power plants will generate a total national capacity of 3063 MW.

There have been several laws in an effort to optimize this geothermal development. One of the most recent laws on geothermal energy, Law No. 21 of 2014, represents a change from the policy of Act

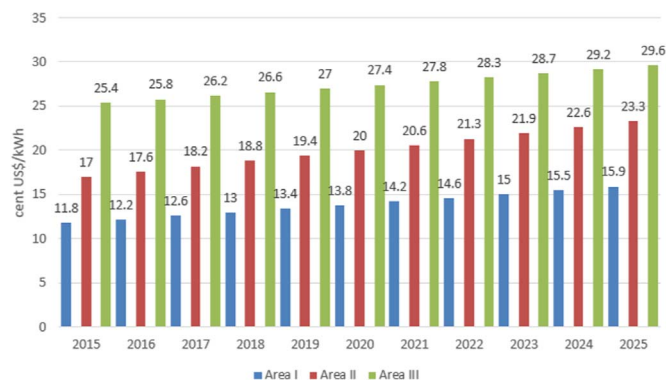

Fig. 7. Electricity benchmark of geothermal selling prices [44]. Future development.

No. 27 of 2003. An important point of revision in the Act of 2014 is that geothermal power generation is no longer classed as a mining operation. This means that geothermal power can be explored on land otherwise set aside for conservation. In the previous Act of 2003, geothermal exploration was counted as part of the mining business, a categorization that raised obstacles to geothermal development. It since most of the potential geothermal energy is located in forested areas where mining activities are not permitted. Even today, when exploration and development of geothermal energy in forests is permitted, overdevelopment could upset the balance of nature. Thus it is necessary to show prudence in managing geothermal areas.

Law 2014 No. 21 has also improved the regulation on the geothermal working areas management. This auction will now be overseen by the central government rather than the district since it has a constraint before in coordination. Other new regulation concern to direct use of geothermal energy for non-electrical purposes such as tourism, agribusiness, and industrial, which should be submitted to local governments for consideration to their revenue.

The price of geothermal energy is one of the biggest policy issues. The ministry regulation in 2014 No. 17 concern in tariffs and subsidies on electricity. There are 13 geothermal working areas constrained by these tariffs as shown in Fig. 7. Prices for geothermal energy vary between regions given the higher production costs in remote areas. Area I, of Sumatra, Java, and Bali, has the most widely available geothermal energy and the lowest selling price benchmark. For 2015, it is set at 11.8 US cents/kWh, and will rise to 12.2 in 2016. By 2019, the benchmark will price will be 13.4 US cents/kWh, and in 2021 it will be 14.2. By 2025 it will be nearly 16 US cents/kWh. Area II, including Sulawesi, NTB, NTT, Halmahera, Maluku, Papua and Kalimantan, has a benchmark about 6 cents higher than Area I, a gap that will grow slightly over the coming years: 17 US cents/kWh in 2015, set to rise to 17.6 in 2016, to 20 cents/kWh by 2020, and 23.3 cents/kWh by 2025 (compare Area I's benchmark of 15.9). And area III contains regions within Areas I and II with isolated transmission systems, which must fulfill their electricity needs from oil-fueled power plants. Because of this, the benchmark selling price of energy is the highest of the three areas. At 25.4 US cents/kWh in 2015, it will rise gradually, less than a cent over the next two years—25.8 cents in 2016, 26.2 in 2017, and 26.6 in 2018. By 2025 the benchmark price in Area III will be 29.6 cents/kWh. Within this tariff the government hope to attract more investors in geothermal development. However, the assurance of this future price should be has a certainty.

5. Conclusion

Indonesia is a country with a relatively broad area, located in Southeast Asia. Its location also lies on the Ring of Fire, a region where continental plates meet around the edges of the Pacific Ocean. This location contributes Indonesia a large geothermal potential. This potential is predicted to be almost 28.91 GW in 312 locations spread

across several islands such as Jawa, Sulawesi, Sumatra, Maluku, Bali and Nusa Tenggara. Unfortunately, less than 5% of this potential is used with an actual current capacity of only 1533.5 MW. This is less utilization than the USA, which has a capacity of 3700 MW, and slightly less than the Philippines, which have a capacity of 1847.69 MW. The small utilization of a large generating capacity is caused by government policy, regulation, human resources, and incentive infrastructure. 11 geothermal plants is operating now including 377 MW in Gunung salak, 270 MW in Darajat, 227 MW in Wayang windu, 230 MW in Kamojang, 60 MW in Dieng 55 MW in Patuha 165 MW in Ulubelu, 12 MW in Sibayak, 80 MW in Lahendong and 2.5 MW in Mataloko as well as 10 MW in Ulumbu. Most of the geothermal reservoirs are water-dominated. However, two reservoirs, Gunung salak and Lahendong, are vapor-dominated.

To further promote the development of geothermal energy, Indonesia has issued several laws in geothermal policy such as Law No. 21 of 2014 represents a change from the policy of Act No. 27 of 2003 shows that geothermal power generation is no longer classed as a mining operation. This means that geothermal power can be explored on land otherwise set aside for conservation. The law also divides the price of geothermal energy into 3 regions. Area I consists of locations in Sumatra, Java, and Bali. Area II includes Sulawesi, NTB, NTT, Halmahera, Maluku, Papua and Kalimantan, while Area III contains regions within Areas I and II with isolated transmission systems.

References

- [1] K.W. Jacquelyne, R. Tilling, This Dynamic Earth [USGS], the Story of Plate Tectonic. [Online]. Available: (<https://pubs.usgs.gov/gip/dynamic/>). [Accessed 09 March 2017].
- [2] A. Wall, K. Young, Doubling Geothermal Generation Capacity by 2020: A Strategic Analysis, 2016.
- [3] Geothermal Basics Potential Use. [Online]. Available: (<http://geo-energy.org/PotentialUse.aspx>). [Accessed 23 February 2017].
- [4] Electric Power Monthly with Data for November 2016, U.S Department of Energy, Washington, 2016.
- [5] Bertani R. Geothermal power generation in the world 2010–2014 update report. *Geothermics* 2016;60:31–43.
- [6] Benito FA, Ogena MS, Stimac JA. Geothermal Energy Development in the Philippines: Country Update. In *Proceedings World Geothermal Congress 2005 Antalya*, Turkey, Antalya, Turkey; 2005.
- [7] Fronda AD, Marasigan MC, Lazaro VS. Geothermal Development in the Philippines: The Country Update, in *World Geothermal Congress 2015*; 2015.
- [8] Ministry of Energy and Mineral Resources, Handbook of Energy & Economic Statistics of Indonesia, 2016th ed. Jakarta; 2016.
- [9] Gutierrez-Negrin LC. Update of the geothermal electric potential in Mexico. *GRC Trans* 2012;36:671–8.
- [10] Energy in New Zealand, Comprehensive information on and analysis of New Zealand's energy supply, demand and prices, Ministry of Business Innovation & Employment; 2016.
- [11] Darma S, Wirakusumah AD. Energy Security and the Role of Geothermal Development in Indonesia. In *World Geothermal Congress 2015*; 2015.
- [12] Fauzi A. Geothermal resources and reserves in Indonesia: an updated revision. *Geotherm Energy Sci* 2015;3:1–6.
- [13] Suhartono, N. Pola sistem panas dan jenis geothermal dalam estimasi cadangan daerah kamojang (in Indonesia), *J. Ilm. MTG*, vol. 5, no. 2; 2012.
- [14] Klasifikasi potensi energi panas bumi di Indonesia (in Bahasa Indonesia), Badan Standarisasi Nasional-BSN, ICS 73.020 SNI-12-5012–1998; 1998.
- [15] Kementerian Energi dan Sumber Daya Mineral, rencana strategis kementerian energi dan sumber daya mineral; 2015.
- [16] Atmojo JP, Itoi R, Tanaka T, Fukuda M, Sudarman S. and Widiyarso, Modeling studies of sibayak geothermal reservoir, northern Sumatra, Indonesia, in *Proceedings World Geothermal Congress 2000*, Kyushu-Tohoku; 2000.
- [17] Atmojo JP, Itoi R, Fukuda M, Tanaka T, Daud Y, Sudarman S. Numerical Modeling Study of Sibayak Geothermal Reservoir, North Sumatra, Indonesia. In: *Proceedings of the Twenty-Sixth Workshop on Geothermal Reservoir Engineering*; 2001.
- [18] Purwono N. Comparison and selection of a steam gathering system in Ulubelu Geothermal Project, Sumatera, Indonesia. United Nations University, Geothermal Training Programme; 2010, [–26].
- [19] Giriario JP, Puspadianti A, Hartanto DB, Siahaan EE. Initial Geochemical Monitoring Ulubelu Geothermal Field. In *World Geothermal Congress 2015*; 2015.
- [20] Yustin Kamah M, Silaban MS. Cooling Indications of The Ulubelu Geothermal System, South Sumatra, Indonesia. In *Cooling Indications of The Ulubelu Geothermal System*, South Sumatra, Indonesia; 2000.
- [21] Peter P, Kusumah YI, Ryder A. Evaluation of Production Multilateral Well in Salak Geothermal Field, Indonesia, in *World Geothermal Congress 2015*; 2015.

- [22] Rozaq K, Rahayu D, Bramantio B. Development of Geothermal in Indonesia -PGE, in *World Geothermal Congress 2015*; 2015.
- [23] "Star Energy Report".
- [24] Purnanto MH, Purwakusumah A. Fifteen Years (Mid-Life Time) of Wayang Windu Geothermal Power Station Unit-1: An Operational Review, in *World Geothermal Congress 2015*; 2015.
- [25] Purnanto MH, Purwakusumah A. Fifteen Years (Mid-Life Time) of Wayang Windu Geothermal Power Station Unit-1: An Operational Review, in *World Geothermal Congress 2015*; 2015.
- [26] T. N, FADILLAH JG Achmad. West Java Geothermal Update. In *Proceedings of the Thirty-Eighth Workshop on Geothermal Reservoir Engineering*; 2013.
- [27] Swandaru RB. Thermodynamic analysis of preliminary design of power plant unit i patuha, West Java, Indonesia; 2006.
- [28] Mansoer AIWR esmiasih. Geothermal resources development in Indonesia: A history. In *World Geothermal Congress 2015*; 2015.
- [29] Ministry of Energy and Mineral Resources of Republic Indonesia. [Online]. Available: (<http://esdm.go.id/>).
- [30] Utami P. Characteristics of The Kamojang Geothermal Reservoir (West Java) as Revealed By Its Hydrothermal Alteration Mineralogy.
- [31] Reza A, Danu S, Irwan EL. Kamojang Geothermal Power Plant Unit 1-2-3 Evaluation and Optimization based on Exergy Analysis. Melbourne, Australia: Presented at the World Geothermal Congress; 2015.
- [32] Yamin W, Choiri M, Goesmano A, Nurfahmiawati T. Darajat Unit II/III Interface Debottlenecking Project. In *World Geothermal Congress 2015*; 2015.
- [33] Pambudi NA, Itoi R, Jalilinasrabady S, Jaelani K. Exergy analysis and optimization of Dieng single-Flash geothermal power plant. *Energy Convers Manag* 2014;78:405–11.
- [34] Sudarman S. History of geothermal exploration in Indonesia from 1970 to 2000. *Geothermics* 2008;37(3):220–66.
- [35] Pambudi NA, et al. The behavior of silica in geothermal brine from Dieng geothermal power plant, Indonesia. *Geothermics* 2015;54:109–14.
- [36] Basoekil M, Radia2 VT. Plan for development of The Lahendong geothermal area North Sulawesi, Indonesia. *Transactions* 1970;3.
- [37] Wahyuningsih, R, Ka. Sitorus, Program pengembangan PLTP skala kecil lapangan panas bumi Todabelu - Mataloko, Ngada, NTT (in Indonesia); 2003.
- [38] Stephanie F. et al., Geothermal Binary Power Plant for Lahendong, Indonesia: A German-Indonesian Collaboration Project Stephanie Frick1, Ali Saadat1, Taufan Surana2, Eben Ezer Siahaan3, Gina Andrea Kupfermann1, Kemal Erbas1, Ernst Huenges1, Mawardi A. Gani3. In *Proceedings World Geothermal Congress 2015*, Melbourne, Australia; 2015.
- [39] Kemal E. et al., German-Indonesian Cooperation on Sustainable Geothermal Energy Development in Indonesia - Status and Perspectives. In *Proceedings World Geothermal Congress 2015*, Melbourne, Australia; 2015.
- [40] Dwipa S, Uchida T, Yasukawa K, Honda M, Andan A. Integrated geophysical exploration in mataloko geothermal area, central flores - east nusatennggara, Presented at the INAGA Annual Scientific Conference & Exhibitions, Yogyakarta; 2001.
- [41] Sulasdi D, Exploration of Ulumbu geothermal field, florest-east Nusa Tenggara, Indonesia. In *Proceedings twenty-first workshop on geothermal reservoir engineering, Stanford University, California*.
- [42] Pre-feasibility study for geothermal power development projects in scattered island of East Indonesia, Engineering and consulting firms association, Japan, March; 2008.
- [43] Agung Prasetyo, The Development of New Renewable Energy and Energy Conservation,; 2014.
- [44] Peraturan Menteri Energi dan Sumber Daya Mineral Republik Indonesia Nomor: 17 Tahun 2014; 2014.